

Product Specification

Product Name: Lithium-ion Cell

Model: HTCFR26650-3600mAh-3.2V

Make By: Wang Fuhui

Checked By: Zhou Hui

Approved By: Li Tao

Shandong Goldencell Electronics Technology Co.,Ltd

Headquarter

Add : Thailand Industrial Park, Hi-tech District,

Zaozhuang

City, Shandong Province, China.

Toll-free telephone : 400-812-5699

Tel: +86-632-5296888

Fax: +86-632-5292918

Postcode : 277800

Email: service@goldencell.biz

Branch office (Shenzhen)

Add: B905, Wuhan University Research Bldg., No. 2 Yue xing Rd., Hi-tech Industrial Park, Nanshan District, Shenzhen, China

Tel: +86-755-28891995

Fax : +86-755-28892486

Postcode : 518057

Web site: www.goldencellbattery.cn

Abstract

1. Application Scope.....	3
2. Model.....	3
3. Appearance and Dimension.....	3
4. Major Technical Parameters.....	3
5. Characteristics Curves.....	4
6. Electrical Characteristics.....	4
7. Safety Characteristics.....	5
8. Environmental Adaptability.....	6
9. Standard Test Environment.....	6
10. Storage and Others.....	6
11. Notice in Using Cell.....	6
12. Disclaimer.....	7
Appendix A.....	8

1. Application Scope

This product specification describes product performance indicators of Lithium-ion cell produced by Shandong Golden-cell Electronics Technology Co., Ltd.

2. Model

HTCFR26650-3600mAh-3.2V

3. Appearance and Dimension

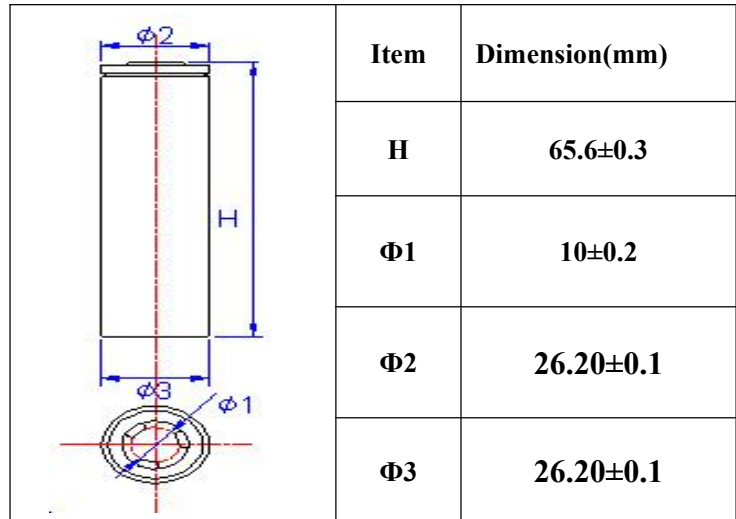

4. Major Technical Parameters

NO.	Item	Standard	Note
1	Standard Capacity	3600mAh	0.2C,(current value of 3600mA at 1C)
2	Minimum Capacity	3550mAh	0.2C
3	Standard Voltage	3.2 V	
4	Alternating Internal Resistance	≤25mΩ	
5	Charge Conditions	Cut-off Voltage	constant-current charge to 3.65V at 0.5C, constant voltage charge to stop until 0.01C mA
		Cut-off Current	
6	Max. Charging Current	3.6A	
7	Discharge Cut-off Voltage	2.5V	
8	Standard Discharge Current	1.8A	
9	Fast Discharge Current	3.6A	This current is the maximum current recommended for the combination of cores, and the specific value should be determined according to the combination structure. The maximum operating current is set at a temperature not exceeding 60 °C.
10	Max. Continuous Discharge Current	10.8A	Only for single cell
11	Pulse Discharge Current	20A, 5s	
12	Cycle Characteristic	2000 times (100%DOD)	the residual capacity is no less than 80% of rated capacity at 1C rate.
		4000 times (80%DOD)	
		7000 times (50%DOD)	

NO.	Item	Standard	Note
13	Working Temperature	Charge: 0°C ~ 55°C	
		Discharge: -20°C ~ 60°C	
14	Storage Temperature	-20°C ~ 55°C	Short-term storage (< 3 months)
15	Cell Weight	Approx 85g	

5. Characteristics Curves

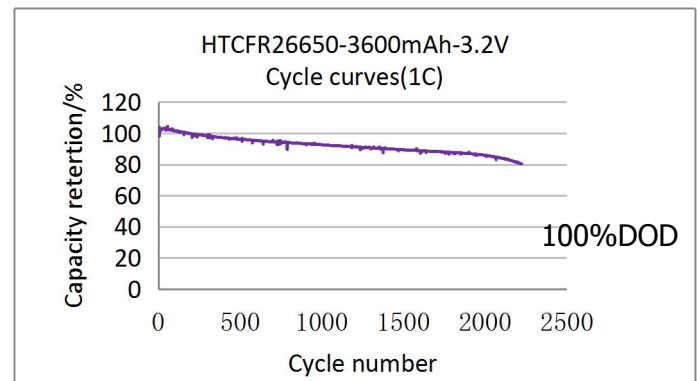
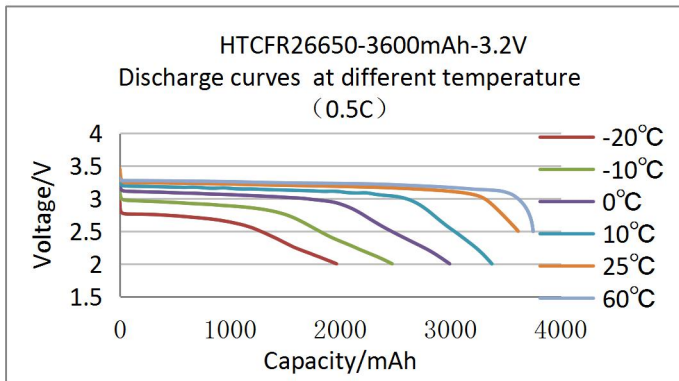
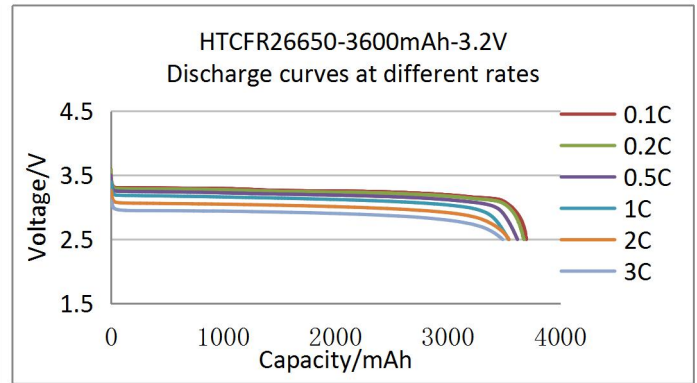
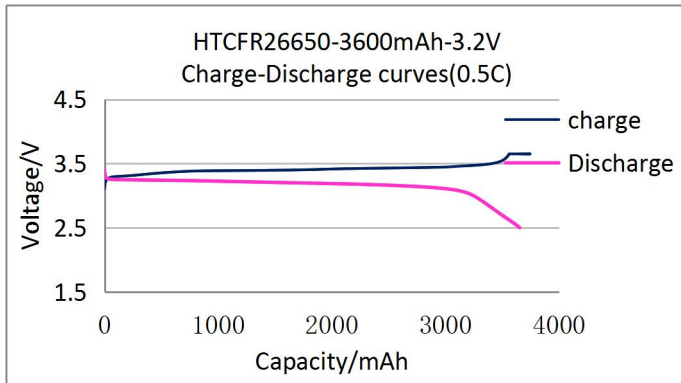

6. Electrical Characteristics

NO.	Item	Test Method	Standard
1	discharge capacity at normal temperature	After full charge, the experiment can be put on hold for 10 minutes; 0.2C discharge to 2.5V allows five repetitions. When the range of three consecutive experiments is less than 3% of the rated capacity, the experiment can be completed ahead of time and the maximum value of the test results can be obtained.	≥3550mAh
2	Discharge performance at different temperatures	After standard charging of normal batteries, it should be stored at least 12 hours in the constant temperature environment of - 20 °C, - 10°C, 0°C, 10 °C and 25 °C, respectively, and 5 hours of 60 °C. Then discharge with 0.5C current to the corresponding termination voltage. When the ambient temperature is more than 15 °C, the termination voltage is 2.5V, if less than 15 °C, which is 2.0V.	discharge capacity /initial capacity *100% -20°C≥40%; 10°C>80; -10°C≥60%; 25°C≥100%; 0°C≥70%; 60°C≥95%.

NO.	Item	Test Method	Standard
3	Discharge performance at normal temperature different rate	After standard charging of normal batteries, it should be placed for 10 minutes at the prescribed ambient temperature. Then discharged to 2.5V at different rates of 0.1C, 0.2C, 0.5C, 1C, 2C and 3C, respectively. The capacity of batteries with different discharge rates was recorded, and the temperature rise T of batteries with different discharge rates was recorded synchronously.	discharge capacity / initial capacity *100% 0.1C: $\geq 100\%$ T: $\leq 5^{\circ}\text{C}$ 0.2C: $\geq 100\%$ T: $\leq 5^{\circ}\text{C}$ 0.5C: $\geq 100\%$ T: $\leq 10^{\circ}\text{C}$ 1C: $\geq 95\%$ T: $\leq 15^{\circ}\text{C}$ 2C: $\geq 90\%$ T: $\leq 25^{\circ}\text{C}$ 3C: $\geq 85\%$ T: $\leq 30^{\circ}\text{C}$
4	Charge retention at normal temperature	Normal batteries are charged according to the standard. They are placed in open circuit for 28 days at room temperature, and then discharged to 2.5V at 0.5C. The recovery capacity of the battery was tested according to the charging and discharging standards.	storage capacity \geq initial capacity *90% recovery capacity \geq initial capacity *95%
5	Charge retention and capacity recovery capability at high temperature	After standard charging, normal batteries are placed open circuit for 7 days in the environment of $55 \pm 2^{\circ}\text{C}$. After the storage period expires, they are placed for 5 hours at room temperature, and then discharged to 2.5V at 0.5C. The recovery capacity of the battery was tested according to the charging and discharging standards	storage capacity \geq initial capacity *90% recovery capacity \geq initial capacity *95%
6	Cycle characteristic	After filling up the battery, stand for 10 minutes, then charge and discharge according to 1C. It is counted as a cycle. The interval between each cycle should not be less than 10 minutes, and the discharge capacity should end when it is less than 80% of the rated capacity.	≥ 2000 times

7. Safety Characteristics

NO.	Item	Test Method	Standard
1	Overcharge	Normal batteries are charged at 1C constant current until the charging termination voltage is 1.5 times or after charging time reaches 1h, then stop charging and the appearance changes of the batteries are observed for 1h.	No explosion, No fire.
2	Over Discharge	After normal charge, test the batteries' initial state. When the batteries are normal, discharge to 0V at 0.5C. Observe cell's variation of appearance.	No explosion, No fire.
3	External Short-circuit	After standard charging of normal batteries, direct short circuit positive and negative poles for 10 minutes, external line resistance should be less than 5 m Ω . When the temperature of batteries drops to 10 $^{\circ}\text{C}$, the test is completed and the appearance changes of batteries are observed for 1 hour.	No explosion, No fire.
4	Thermal Abuse	The initial state of the normal battery was measured. After standard charging, the battery was placed in the oven. The temperature was increased to $130 \pm 2^{\circ}\text{C}$ at a rate of $(5 \pm 2^{\circ}\text{C})/\text{min}$ and kept for 30 minutes. Then the appearance of the battery was observed for one hour.	No explosion, No fire.
5	Drop	After standard charging of normal batteries, the initial state of the batteries was measured, and the test batteries were freely dropped from 1.5m height to flat cement ground, once in each direction.	No explosion, No fire.
6	Heavy Impact	A diameter of 15.8 mm steel rod is placed in the middle of the fully charged cell, then the weight of 10kg hammer from 1.0m height free falls to the cell upper.	No explosion, No fire.

NO.	Item	Test Method	Standard
7	Extrusion Test	After standard charging of normal batteries, pressure is applied perpendicular to the electrode plate or the longitudinal axis of batteries. The area of extrusion head is not less than 20 cm ² , and the pressure gradually increases to 13 kN or the deformation reaches 30%.	No explosion, No fire.
8	Prick test	Use $\Phi 3 \sim 5$ mm high temperature resistant steel needle, to 10 mm/s \sim 40 mm/s of speed, from the perpendicular to the direction of the cell plate. (The steel needle stays in battery for more than 5 minutes).	No explosion, No fire.

8. Environmental Adaptability

NO.	Item	Test Method	Standard
1	Thermal Cycle	Store the cell for 48 hours at $75 \pm 2^\circ\text{C}$ after standard charge, then store the cell at -20°C for 6 hours, and at room temperature for 24 hours. Observe the batteries' appearance.	No leakage, No smoke, No fire, No explosion.
2	Static Humidity	Put the cell at $40^\circ\text{C} \pm 5^\circ\text{C}$ and 95%RH chamber for 48h, then get it out and store it for 2h at room temperature. Observe the appearance and discharge at 0.5C to 2.5V, then test the final capacity.	Discharge capacity after storage is more than 90% of rated capacity. No obvious outside damage, No corrosion, No smoke, No explosion
3	Vibration	Standard charge. Equip it to the vibration platform, prepare the test equipment according to following vibration frequency and relevant swing, doing frequency sweeping from X, Y, Z three directions, each from 10Hz to 55Hz for 30 minutes of recycling, rating of which is 1oct/min: A)vibration frequency:10Hz \sim 30Hz Displacement breadth (single swing): 0.38mm B)vibration frequency:30Hz \sim 55Hz Displacement breadth (single swing): 0.19mm. Observe the final state after scanning.	Residual Capacity $\geq 90\%$ Rated Capacity Voltage Decrease Rate $\leq 0.5\%$ No obvious outside damage, No leakage, No smoke, No explosion.

9. Standard Test Environment

Unless especially specified, all tests stated in this Product Specification are conducted at below condition:

Temperature: $25 \pm 2^\circ\text{C}$

Humidity: $(65 \pm 20)\%$ RH

10. Storage and Others

10.1 Long Time Storage

It should be stored in dry and cool place if the cell is stored for a long time (more than three months), Storage ambient temperature is required to be $25 \pm 5^\circ\text{C}$, humidity is required to be less than 85% RH. And in order to ensure that the environmental control under this condition cannot make the surface of the cell appear condensate droplets, while the surface of the storage cell cannot appear moisture phenomenon. The batteries' storage voltage should be 3.3~3.4V and the cell should be stored in a condition as NO.8.

10.2 Other considerations

Any matters that this specification does not cover should be consulted between the customer and Goldencell.

11. Notice in Using Cell

Abuse of cell may cause accidents such as damage to cores or personal injury. So please read the following safety codes and precautions carefully before used:

- Do not immerse the cell in water or seawater, and keep the cell in a cool dry surrounding if it stands by.
- Do not use or leave the cell at high temperature as fire or heater. Otherwise, it can overheat or fire or its performance will be degenerate and its service life will be decreased.
- Do not reverse the position and negative terminals.
- Do not connect the cell electrodes to an electrical outlet.
- Do not short circuit. Otherwise it will cause serious damage of the cell.
- Do not transport or store the cell together with metal objects such as hairpins, necklaces, etc.
- Do not strike, trample, throw, fall and shock the cell.
- Do not directly solder the cell and pierce the cell with a nail or other sharp objects.
- Do not use the cell in a location where static electricity and magnetic field is great, otherwise, the safety devices may be damaged, causing hidden trouble of safety.
- Use the cell charger specifically when recharging.
- If the cell leaks and the electrolyte gets into the eyes, do not rub the eyes, instead, rinse the eyes with clean water, and immediately seek medical attention. Otherwise, it may injure eyes.
- If the cell gives off strange odor, generates heat, becomes discolored or deformed, or in any way appears abnormal during use, recharging or storage, immediately stop charging, using, and remove it from the device.
- In case the cell terminals are dirty, clean the terminals with a dry cloth before use. Otherwise poor performance may occur due to the poor connection with the instrument.
- Tape the discarded cell terminals to insulate them.

12. Disclaimer

Quality assurance does not include normal wear and tear, as well as problems caused by improper maintenance, handling and storage. Failure to follow the use and installation specified in this product specification, including but not limited to the following:

- Damage during transportation or storage.
- Problems arising from the combination of circuit, batteries and chargers.
- Incorrect battery installation or maintenance.
- Use cell or cell pack in inappropriate environments.
- Used improper or incorrect charging and discharging methods which is not included in this specification.
- Failure to comply with operational precautions.
- Bad battery cells generated in the process of assembling by the customer after shipment.
- In case of force majeure, such as lightning, storm, flood, fire, earthquake, etc.

The Company shall not be responsible for any direct or indirect damage caused by or related to the product not being assembled or used as required.

Appendix A

Suggestions for Cell Packs

1. Selecting principle of nickel strip is often applied to the design of cell packs.

Based on the working current of cell packs to make the shunt selection of nickel strip. The common nickel strip could under the current as below:

Nickel Strip Type	3*0.1	4*0.1	7*0.15	8*0.15
Normal Working Current	2A	3A	7A	8A
Maximum Continues Current	4A	5A	13A	15A

2. Relation between the cell packs design current and lead wires current breakdown, and principle of wires selection.

Based on the working current of cell packs to make the shunt selection of wires. Different wires could under the current as below:

AWG	Diameter		Cross-sectional mm ²	resistance Ω/km	normal current A	Max- current A	AWG	Diameter		Cross-sectional mm ²	resistance Ω/km	normal current A	Max- current A
	Metric/mm	Imperial/inch						Metric/mm	Imperial/inch				
0000	11.68	0.46	107.22	0.17	423.2	482.6	22	0.643	0.0253	0.3247	54.3	1.280	1.460
000	10.4	0.4096	85.01	0.21	335.5	382.6	23	0.574	0.0226	0.2588	48.5	1.002	1.165
00	9.27	0.3648	67.43	0.26	266.2	303.5	24	0.511	0.0201	0.2047	89.4	0.808	0.921
0	8.25	0.3249	53.49	0.33	211.1	240.7	25	0.44	0.0179	0.1624	79.6	0.641	0.731
1	7.35	0.2893	42.41	0.42	167.4	190.9	26	0.404	0.0159	0.1281	143	0.506	0.577
2	6.54	0.2576	33.62	0.53	132.7	151.3	27	0.361	0.0142	0.1021	128	0.403	0.460
3	5.83	0.2294	26.67	0.66	105.2	120.0	28	0.32	0.0126	0.0804	227	0.318	0.362
4	5.19	0.2043	21.15	0.84	83.5	95.2	29	0.287	0.0113	0.0647	289	0.255	0.291
5	4.62	0.1819	16.77	1.06	66.2	75.5	30	0.254	0.0100	0.0507	361	0.200	0.228
6	4.11	0.0162	13.3	1.33	52.5	59.9	31	0.226	0.0089	0.0401	321	0.158	0.181
7	3.67	0.1443	10.55	1.68	41.6	47.5	32	0.203	0.0080	0.0316	583	0.128	0.146
8	3.26	0.1285	8.37	2.11	33.0	37.7	33	0.18	0.0071	0.0255	944	0.101	0.115
9	2.91	0.1144	6.63	2.67	26.2	29.8	34	0.16	0.0063	0.0201	956	0.079	0.091
10	2.59	0.1019	5.26	3.36	20.8	23.7	35	0.142	0.0056	0.0169	1200	0.063	0.072
11	2.3	0.0907	4.17	4.24	16.5	18.8	36	0.127	0.0050	0.0127	1530	0.050	0.057
12	2.05	0.0808	3.332	5.31	13.1	14.9	37	0.114	0.0045	0.0098	1377	0.041	0.046
13	1.82	0.0720	2.627	6.69	10.4	11.8	38	0.102	0.0040	0.0081	2400	0.032	0.036
14	1.63	0.0641	2.075	8.45	8.2	9.4	39	0.089	0.0035	0.0062	2100	0.025	0.028
15	1.45	0.0571	1.646	10.6	6.5	7.4	40	0.079	0.0031	0.0049	4080	0.019	0.022
16	1.29	0.0508	1.318	13.5	5.2	5.9	41	0.071	0.0028	0.004	3685	0.016	0.018
17	1.15	0.0453	1.026	16.3	4.1	4.7	42	0.064	0.0025	0.0032	6300	0.013	0.014
18	1.02	0.0403	0.8107	21.4	3.2	3.7	43	0.056	0.0022	0.0025	5544	0.010	0.011
19	0.912	0.0369	0.5667	26.9	2.6	2.9	44	0.051	0.0020	0.002	10200	0.008	0.009
20	0.813	0.032	0.5189	33.9	2.0	2.3	45	0.046	0.0018	0.0016	9180	0.006	0.007
21	0.724	0.0285	0.4116	42.7	1.6	1.9	46	0.041	0.0016	0.0013	16300	0.005	0.006

3. Voltage protection point value (for single cell) of protection board or BMS, and selecting principle of protection board.

	Over-charged Protection Voltage	Over-discharged Protection Voltage	The protection voltage point for monomer should be selected also based on the safety voltage point of cell and protection voltage point of IC.
Lithium Iron Phosphate	3.6-3.9	2.0-2.5	
Ni-Co- Mn	4.05-4.25	2.5-3.0	

Selecting principles of protection board: based on the safety needs of the cell and customers' requirements. To select the suitable protection board according to the size of cell packs.

4. Selecting principles of chargers.

- (1) Voltage should be regulated by the safest voltage of chargeable cell * n (make the Lithium iron phosphate as 3.6 V and Ni- Co- Mn as 4.2 V).
- (2) Current should be limited by the safe current of chargeable cell, and the customers' specific requirements also should be considered.

(3) If above 120W, chargers with aluminium alloy cooling fin or cooling fan will be suggested.

(4) If under 60W, chargers with plastic shell will be suggested.

5. In the process of packs structure design and production, some measures and skills could be handled to avoid cell short circuit.

(1) To strengthen the positive insulation treatment of the monomer batteries, with barley paper or other high temperature resistant material.

(2) Cell in the case of size allowed, should try to use batteries of the isolation.

(3) Cell when working current is larger and can't use bracket, should strengthen the insulation of the batteries shell, for example, using paper sleeve, PVC casing.

(4) The power line shall not directly contact with the surface of the batteries, avoid cross; Must cross the line and the line between the bracket with high temperature tape or barley paper.

(5) Power line is not connected to the nickel spot welding surface as far as possible, cannot be avoided, the power line between nickel and high temperature insulation tape to stick a highland barley paper.

(6) The reasonable design of nickel welding way, minimize nickel piece of calorific value.