

1.- Introduction

This specification governs the performance of the following FULLWAT Nickel-Metal Hydride Cylindrical cell (NH3800AJF) and its stack-up batteries.

2.- Data of stack up batteries

All data involves and weight to stack-up battery are equal to the value of unit cell time the number of unit cell which consisted in the stack batteries.

3.- Ratings

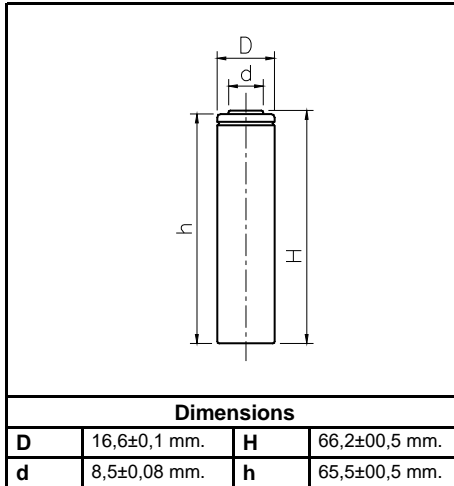

Nominal capacity		3800 mAh	
Nominal voltage		1,2 V	
Charge current	Pulse	< 190 mAh	
	Standard	380 mAh	
	Quick	1140 mAh	
Charge time	Pulse	No limit	
	Standard	14 ~ 16 hrs	
	Quick	4 hrs	
Temperature	Charge	Standard	0 ~ 45 °C
		Quick	10 ~ 45 °C
	Discharge	-20 ~ 60 °C	
	Storage	-20 ~ 55 °C	
Impedance (mohmios) (After charge)		Máx. 20	
Weight		54 grs.	

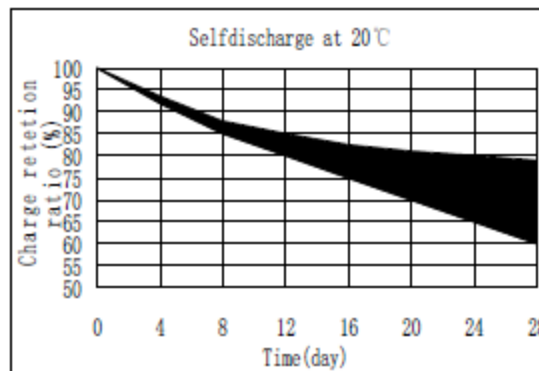
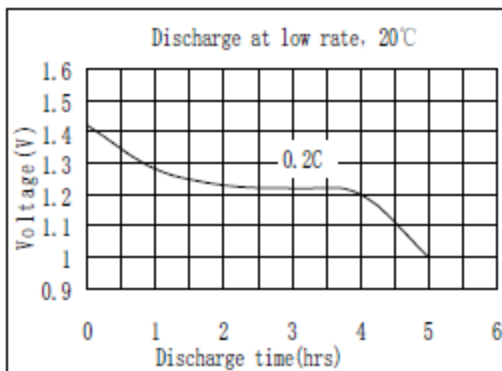
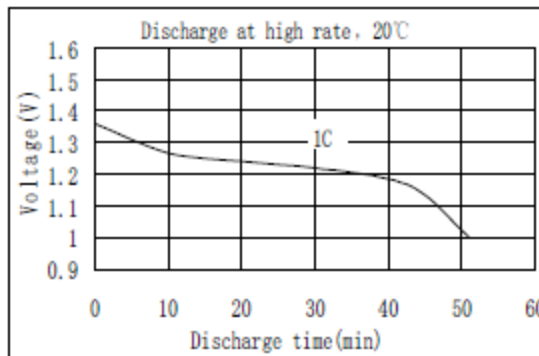
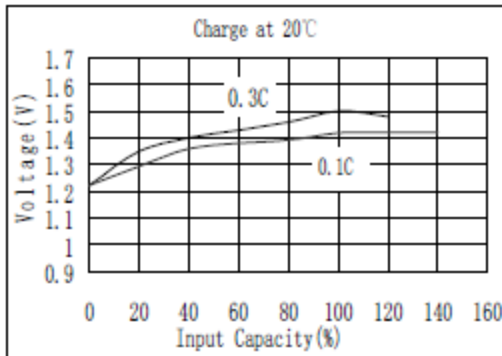

4.- Configuration and dimensions

See attached graphics.

5.- Performance

Unless otherwise stated, tests should be done within one month of delivery under the following conditions:

Ambient temperature (T1):	20 ± 5 °C
Relative humidity	60 ± 20 %
Charge conditions	380 mA (C/10) x 16 hours
Discharge conditions	760 mA (C/5) to 1,0 V/cell

Test	Unit	Value	Conditions	Remarks
Capacity	mAh	> 3700	Standard charge discharge	Up to 3 cycles are allowed
Open circuit voltage (VOC)	V/cell	> 1,25	Within 1 hour after standard charge	
Internal impedance	mohms/cell	Maximum < 20	Upon fully charge (1KHz)	
High rate discharge (1C)	Minute	> 51	Standard charge, 1 hour rest before discharge by 3800 mA (1C) to 1,0 V/cell	Up to 3 cycles are allowed
Overcharge		No leakage nor explosion	380 mA (C/10). Charge 28 days.	
Charge retention	mAh	> 2280 (60 %)	Standard charge. Storage: 28 days. Standard discharge.	
Cycle life	Cycle	> 500	IEC61951-2(2003)7.4.1.1	
Leakage		No leakage nor explosion	Fully charge at 380 mA 1h.	
Vibration resistance		Change of voltage should be under 0,02V/cell, change of impedance should be under 5 mohms/cell.	Charge the battery at C/10 for 14 hours, Then leave for 24 hrs, check battery before/after vibration. Amplitude 1,5 mm.. Vibration 3000 CPM. Any direction for 60 min.	
Impact resistance		Change of voltage should be under 0,02V/cell, change of impedance should be under 5 mohms/cell.	Charge the battery at C/10 for 14 hours, Then leave for 24 hrs, check battery before/after dropped. Height = 50 cm. Wooden board (thickness 30mm) Direction not specified, 3 times.	

6.- External appearance

The cell/battery shall be free from cracks, scars, breakage, rust, discoloration, leakage nor deformation.

7.- Warranty

One year limited warranty against workmanship and material defects.

8.- Caution.

- Reverse charging is not acceptable.
- Charge before use. The cells/batteries are delivered in an uncharged state.
- Do not charge/discharge with more than our specified current.
- Do not short circuit the cell/battery. Permanent damage to the cell/battery may result.
- Do not incinerate or mutilate the cell/battery.
- Do not solder directly to the cell/battery.
- The life expectancy may be reduced if the cell/battery is subjected adverse conditions like: extreme temperature, deep cycling , excessive overcharge/ over-discharge.
- Store the cell/battery uncharged in a cool dry place. Always discharge batteries before bulk storage or shipment.