

HA12-1.2 (12V-1.2 Ah)



Specifications

Nominal Voltage	12V	
Rated capacity (20 hour rate)	1.2Ah	
Dimensions	Length	98 ± 1mm(3.86inch)
	Width	43 ± 1mm(1.69inch)
	Height	52 ± 1mm(2.05inch)
	Total Height	58 ± 1mm(2.28inch)
Approx. Weight	0.54kg(1.19lbs) ± 5%	

Dimensions (mm)

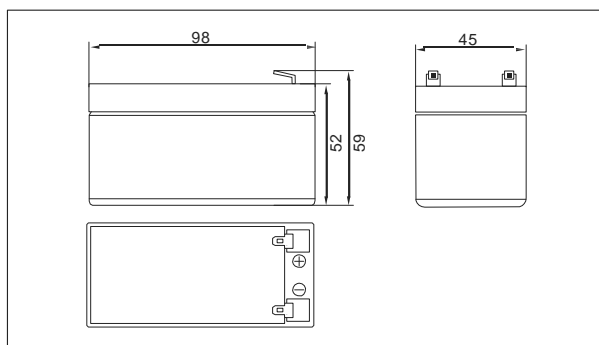

Terminal Type (mm)

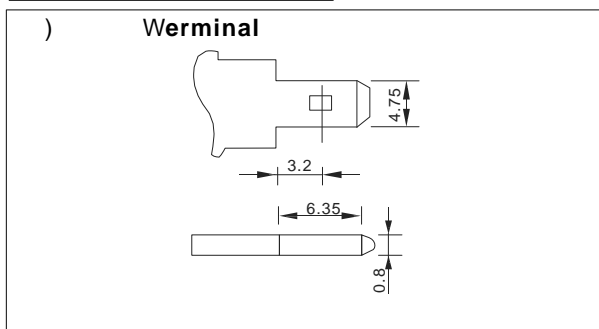

Characteristics

Capacity (25 °C)	20HR(10.5V)	1.2Ah
	10HR(10.5V)	1.1Ah
	1HR(9.60V)	0.72Ah
Terminal type		T1
Internal resistance (Fully charged, 25 °C)		Approx. 90m Ω
Capacity affected by temperature (20HR)	40	102%
	25	100%
	0	85%
	-15	65%
Self-discharge (25 °C)	3month	Remaining Capacity: 91%
	6month	Remaining Capacity: 82%
	12month	Remaining Capacity: 65%
Nominal operating temperature		25 ± 3 (7 / ± 5 °C)
Operating temperature range	Discharge	-15 ~ 5 (5 / ~122 °F)
	Charge	-10 ~ 5 (4 / ~122 °F)
	Storage	-20 ~ 5 (-4 / ~122 °F)
Float charging voltage(25 °C)		13.50 to 13.80V Temperature compensation: -18mV/°C
Cyclic charging voltage(25 °C)		14.50 to 15.00V Temperature compensation: -30mV/°C
Maximum charging current		0.36A
Maximum discharge current		18A(5 sec.)
Designed floating life(20 °C)		5 years

Construction

Component	Positive plate	Negative plate	Container	Cover	Separator	Electrolyte	Safety valve	Terminal
Raw material	Lead dioxide	Lead	ABS	ABS	AGM	Sulfuric acid	Rubber	Copper

Constant Current Discharge Characteristics Unit:A(25 °C, 77 °F)

F.V/Time	5min	10min	15min	30min	60min	2h	3h	4h	5h	10h	20h
9.60V	4.58	2.90	2.27	1.28	0.79	0.43	0.30	0.25	0.21	0.11	0.06
9.90V	4.45	2.82	2.21	1.25	0.77	0.43	0.30	0.24	0.21	0.11	0.06
10.2V	4.26	2.70	2.13	1.21	0.75	0.42	0.29	0.24	0.21	0.11	0.06
10.5V	4.08	2.58	2.06	1.18	0.74	0.42	0.29	0.24	0.21	0.11	0.06
10.8V	3.85	2.44	1.95	1.14	0.72	0.41	0.28	0.23	0.20	0.11	0.06

Constant Power Discharge Characteristics Unit:W(25 °C, 77 °F)

F.V/Time	5min	10min	15min	30min	60min	2h	3h	4h	5h	10h	20h
9.60V	51.2	32.8	25.9	14.6	9.10	5.03	3.53	2.93	2.50	1.36	0.73
9.90V	49.6	31.8	25.2	14.4	8.97	5.00	3.51	2.91	2.48	1.36	0.73
10.2V	47.6	30.5	24.3	13.9	8.74	4.96	3.49	2.89	2.47	1.35	0.72
10.5V	45.5	29.2	23.5	13.6	8.56	4.88	3.46	2.87	2.45	1.34	0.72
10.8V	43.0	27.5	22.2	13.1	8.30	4.76	3.36	2.79	2.38	1.32	0.71

Note: The above characteristics data can be obtained within three charge or discharge cycles.

HA12-1.2 (12V-1.2 Ah)

Discharge characteristics (25°C)

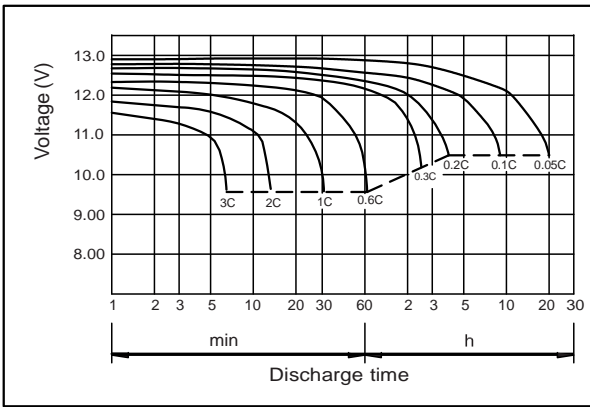

Charging characteristics (25°C)

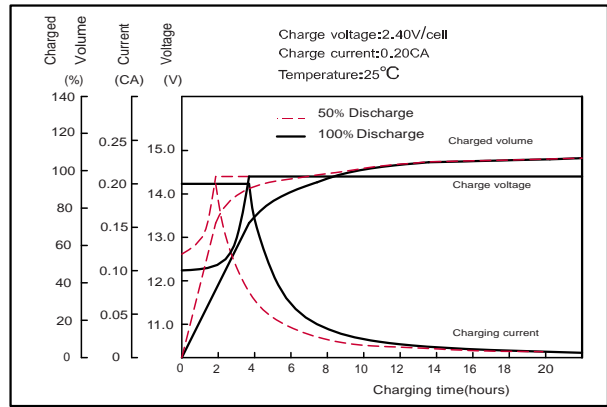

Effect of temperature on capacity

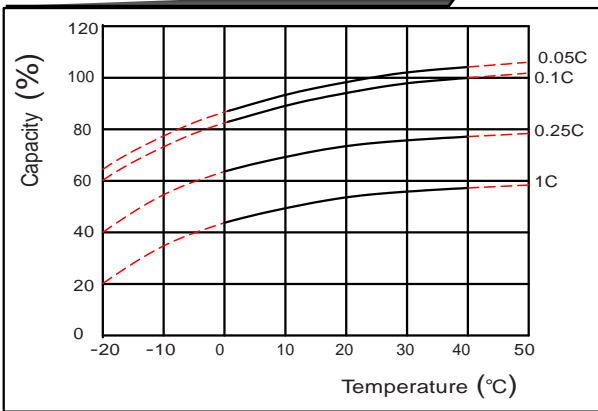

Self-discharge

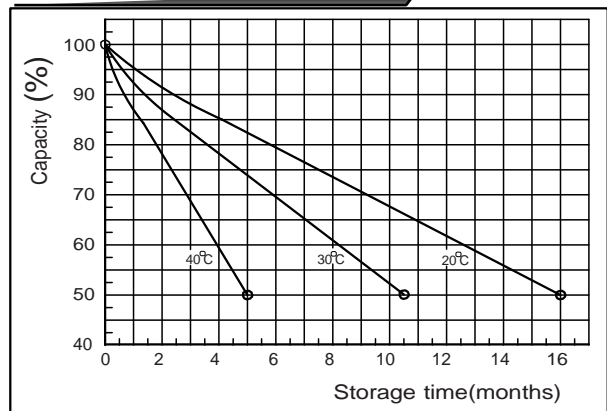

Floating life vs temperature

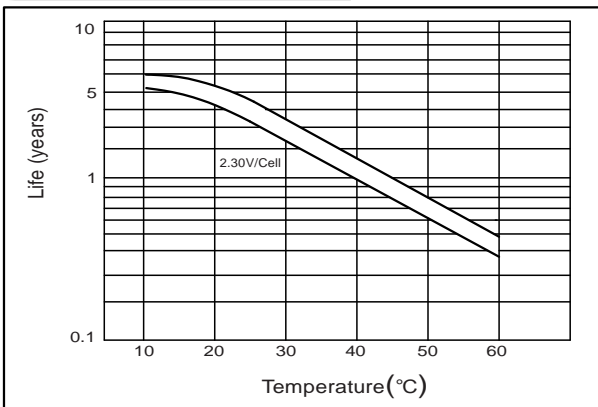

Cycle life vs D.O.D (25°C)

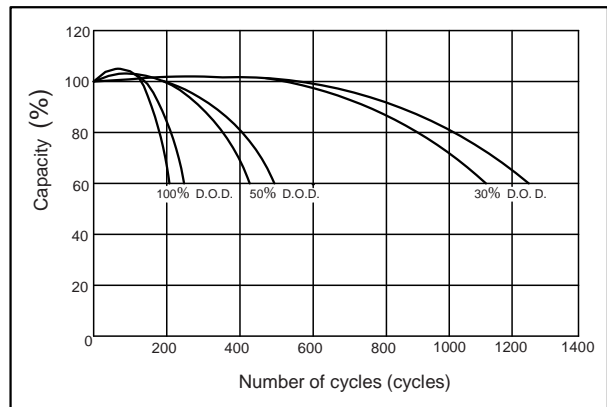

OCV vs Capacity (25°C)

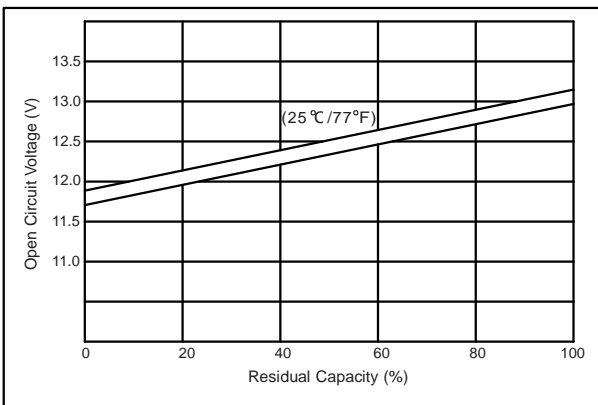

Charging voltage and Temperature

