

KB612 6V 1.2Ah



The KB Standard series consists in VRLA batteries - AGM technology (Absorbent Glass Mat), with a design life of 3-5 years and it is designed for general applications such as UPS, telecommunications and electrical applications.



Performance Characteristics

Nominal Voltage	6V		
Dimensions	Length (mm / inch)	97 / 3.82	
	Width (mm / inch)	24 / 0.94	
	Height (mm / inch)	52 / 2.05	
	Total Height (mm / inch)	58 / 2.28	
Approx Weight	(Kg / lbs)	0.31 / 0.68	
Design Life	5 years		
Terminal	F1		
Container Material	ABS		
Rated Capacity	1.2Ah / 0.06A	(20hr, 1.80V / cell, 25°C / 77°F)	
	1.1Ah / 0.11A	(10hr, 1.80V / cell, 25°C / 77°F)	
	1.05Ah / 0.21A	(5hr, 1.75V / cell, 25°C / 77°F)	
	0.82Ah / 0.82A	(1hr, 1.60V / cell, 25°C / 77°F)	
Max. Discharge Current	18A (5s)		
Internal Resistance	Approx 50mΩ		
Operating Temp. Range	Discharge : -20 ~ 60°C (-4 ~ 140°F)		
	Charge : -10 ~ 60°C (14 ~ 140°F)		
	Storage : -20 ~ 60°C (-20 ~ 140°F)		
Nominal Operating Temp. Range	25 ± 3°C (77 ± 5°F)		
Cycle Use	Initial Charging Current less than 0.24A		
	Voltage: 7.2V ~ 7.35V at 25°C (77°F)		
	Temp. Coefficient: -15mV/°C		
Standby Use	Initial Charging Current less than 0.24A		
	Voltage: 6.75V ~ 6.9V at 25°C (77°F)		
	Temp. Coefficient: -10mV/°C		
Capacity affected by Temperature	40°C (104°F)	103%	
	25°C (77°F)	100%	
	0°C (32°F)	86%	
Self Discharge	Fully charged Kaise Standard Series batteries may be stored for up to 6 months at 25°C (77°F) and then a freshening charge is required. For higher temperatures the time interval will be shorter.		

Discharge Constant Current (Amperes) at 77°F (25°C)

Volts/cell	5min	10min	15min	30min	1h	3h	5h	10h	20h
1.80V	3.55	2.61	1.95	1.08	0.63	0.31	0.21	0.11	0.06
1.75V	4.00	2.88	2.11	1.21	0.69	0.33	0.21	0.11	0.06
1.70V	4.36	3.12	2.27	1.31	0.75	0.35	0.21	0.11	0.06
1.65V	4.71	3.34	2.40	1.39	0.79	0.36	0.22	0.11	0.06
1.60V	5.00	3.50	2.50	1.45	0.82	0.36	0.22	0.11	0.06

Dimensions and Terminal (Unit: mm (inches))

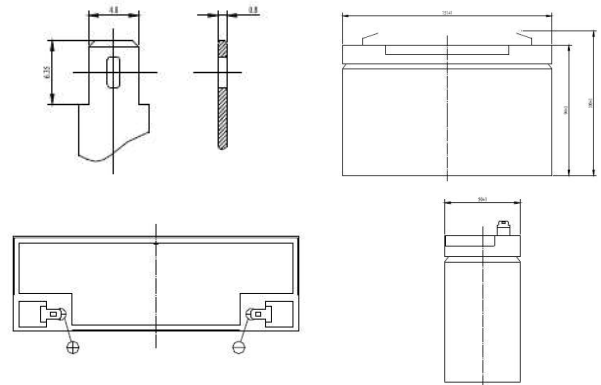

Applications

- | | |
|----------------------------|---------------------------------------|
| Alarm systems | Marine equipment |
| Cable television | Medical equipment |
| Communications Equipment | Micro processor based office machines |
| Control Equipment | Portable cine & Video lights |
| Computers | Solar powered systems |
| Electronic Cash Registers | Telecommunications systems |
| Electric Test Equipment | Television & Video recorders |
| Emergency lighting systems | Toys |
| Fire & Security | Uninterruptible power supply systems |
| Geophysical equipment | Vending machines |

Certifications

ISO 9001:2008 ISO 14001:2008



Discharge Current vs. Discharge Voltage

Final discharge voltage V/CELL	1.8	1.75	1.7	1.6
Discharge current [A]	$I \leq 0.1CA$	$0.25CA \geq I > 0.1CA$	$0.55CA \geq I > 0.25CA$	$I > 0.55CA$

Discharge Constant Power (Watts per cell) at 77°F (25°C)

Volts/cell	5min	10min	15min	30min	45min	1h	2h	3h	5h
1.80V	5.84	4.56	3.61	2.13	1.52	1.21	0.73	0.54	0.48
1.75V	6.44	5.02	4.02	2.34	1.71	1.37	0.83	0.61	0.48
1.70V	6.93	5.40	4.33	2.50	1.87	1.47	0.90	0.65	0.48
1.65V	7.38	5.73	4.58	2.63	1.99	1.58	0.96	0.69	0.50
1.60V	8.80	6.02	4.80	2.75	2.08	1.64	1.00	0.72	0.50

(Note) The above characteristics data are average values obtained within three charge/discharge cycles not the minimum values.

Charging Characteristics (float use)

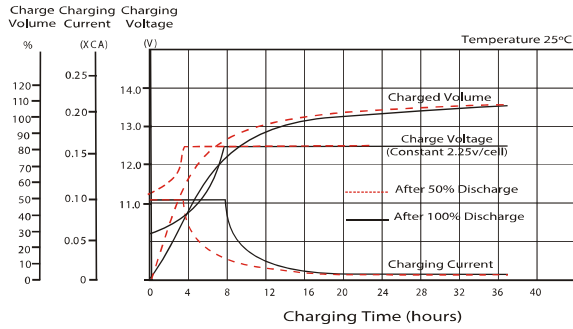

Cycle Life in Relation to Depth of Discharge

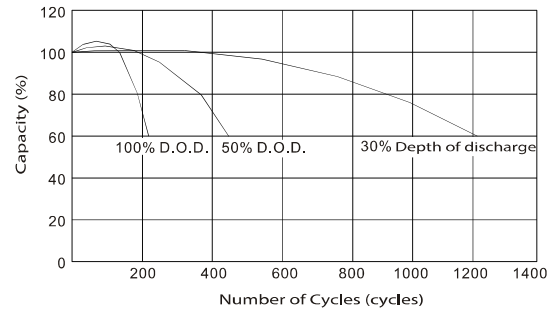

Temperature Effects in Relation to Battery Capacity

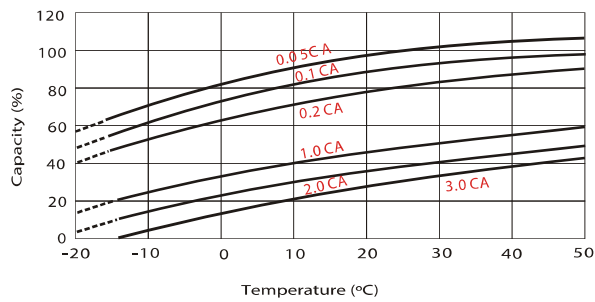

Effect of Temperature on Long Term Float Life

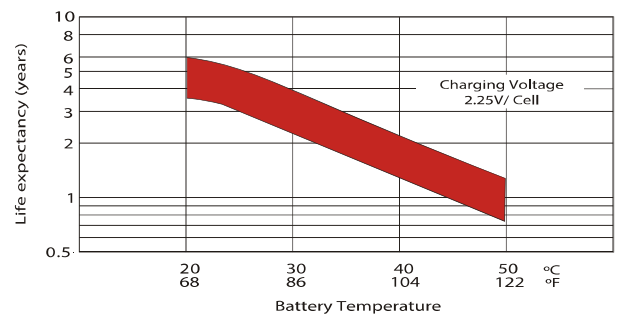

Self Discharge Characteristics

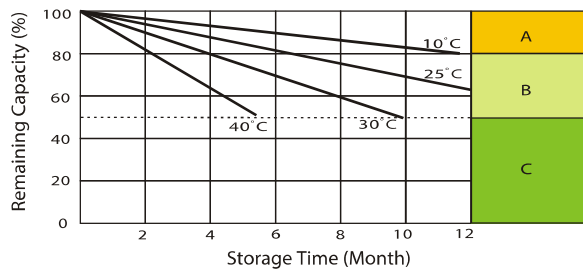

- A** No supplementary charge required
(carry out supplementary charge before use if 100% capacity is required)
- B** Supplementary charge required before use. Optional charging way as below:
 1. Charged for above 3 days at limited current 0.25 CA and constant voltage 2.25V / cell.
 2. Charged for above 20 hours limited current 0.25CA and constant voltage 2.45V / cell.
 3. Charged for 8-10 hours at limited current 0.05 CA.
- C** Supplementary charge often fail to recover the capacity.
The battery should never be left standing till this is reached.

IMPORTANT NOTE: The specifications presented herein are subject to revision without notice.