

KBG12800 12V 80Ah (C₂₀)



Gel battery shows some distinctive advantages over flooded battery or AGM battery, such as super thermal stability, high deep discharge capability, good recovery from deep discharge, even if the battery is left discharged for three days, it will recover to 100% of capacity. With the above-mentioned advantages, the gel battery has long service life, specially suitable for motive power applications, such as golf trailer, scrubber, folklift, etc. The deep discharge cycles increased 50% as compared with the AGM battery.

Performance Characteristics

Nominal Voltage	12V	
Design Life	12 years	
Dimensions	Length (mm / inch)	350 / 13.8
	Width (mm / inch)	167 / 6.57
	Height (mm / inch)	179 / 7.05
	Total Height (mm / inch)	179 / 7.05
Approx. Weight	(Kg / lbs) 22.5 / 49.6	
Terminal	M8	
Container Material	ABS	
Rated Capacity	80.0Ah / 4.00A	(20hr, 1.75V / cell, 25°C / 77°F)
	75.7Ah / 7.57A	(10hr, 1.70V / cell, 25°C / 77°F)
	67.5Ah / 13.5A	(5hr, 1.70V / cell, 25°C / 77°F)
	46.6Ah / 46.6A	(1hr, 1.70V / cell, 25°C / 77°F)
Max. Discharge Current	750A (5s)	
Internal Resistance	Approx 7.0mΩ	
Operating Temp. Range	Discharge : -20 ~ 60°C (-4 ~ 140°F)	
	Charge : -10 ~ 60°C (14 ~ 140°F)	
	Storage : -20 ~ 60°C (-4 ~ 140°F)	
Nominal Operating Temp. Range	25 ± 3°C (77 ± 5°F)	
Cycle Use	Maximum charging current 16A	
	Voltage: 14.4V ~ 14.7V at 25°C (77°F)	
	Temp. Coefficient: -20mV/°C	
Standby Use	Maximum charging current 16A	
	13.5V ~ 13.8V at 25°C (77°F)	
	Temp. Coefficient: -30mV/°C	
Capacity affected by Temperature	40°C (104°F)	103%
	25°C (77°F)	100%
	0°C (32°F)	86%
Self Discharge	Fully charged Kaise Gel Series batteries may be stored for up to 6 months at 25°C (77°F) and then a freshening charge is required. For higher temperatures the time interval will be shorter.	

Discharge Constant Current (Amperes) at 77°F (25°C)

Volts/cell	10min	15min	30min	1h	3h	5h	10h	20h
1.80V	143	114	72.8	45.1	19.2	13.1	7.34	3.94
1.75V	153	122	75.3	45.9	19.7	13.3	7.52	4.00
1.70V	161	127	77.9	46.6	20.1	13.5	7.57	4.05
1.65V	171	132	80.5	47.4	20.5	13.7	7.62	4.07
1.60V	180	138	83.1	48.2	20.9	13.9	7.67	4.12

Dimensions and Terminal (Unit: mm (inches))

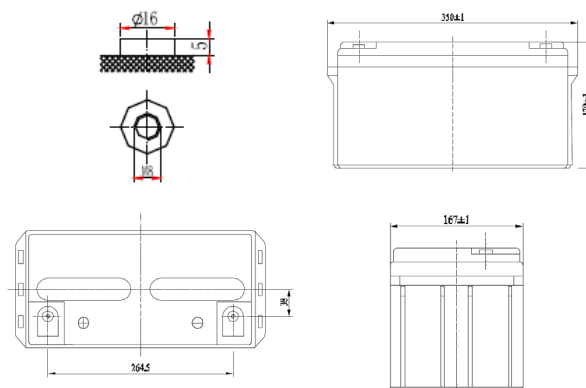

Applications

Wind and solar energy systems
 Cable TV systems
 Telecommunications
 Electric wheel chairs
 Military equipment
 Emergency lighting
 Power plants
 Medical equipment
 Golf carts

Certifications

ISO 9001:2008 ISO 14001:2008



Discharge End Voltage vs. Discharge Current

Final discharge voltage V/CELL	1.8	1.75	1.7	1.6
Discharge current (A)	I ≤ 0.1CA	0.25CA ≥ I > 0.1CA	0.55CA ≥ I > 0.25CA	I > 0.55CA

Discharge Constant Power (Watts per cell) at 77°F (25°C)

Volts/cell	10min	15min	30min	1h	3h	5h
1.80V	260	223	144	98.5	37.6	26.5
1.75V	276	237	147	99.5	38.4	26.8
1.70V	291	247	151	100	38.9	27.0
1.65V	306	255	156	101	39.5	27.3
1.60V	322	264	160	102	40.0	27.5

(Note) The above characteristics data are average values obtained within three charge/discharge cycles not the minimum values.

Charging Characteristics (cycle use)

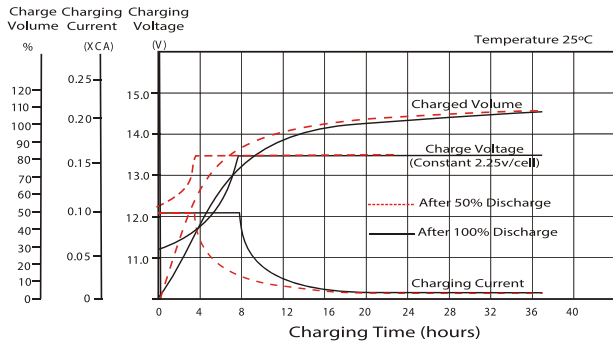

Cycle Life in Relation to Depth of Discharge

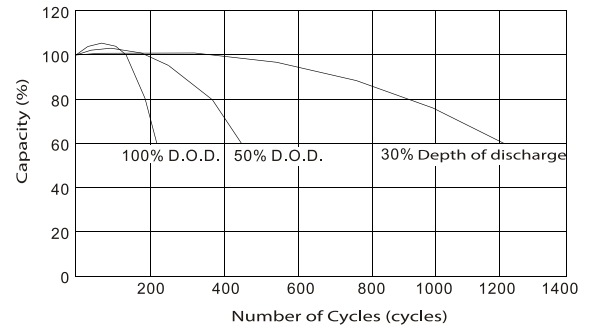

Temperature Effects in Relation to Battery Capacity

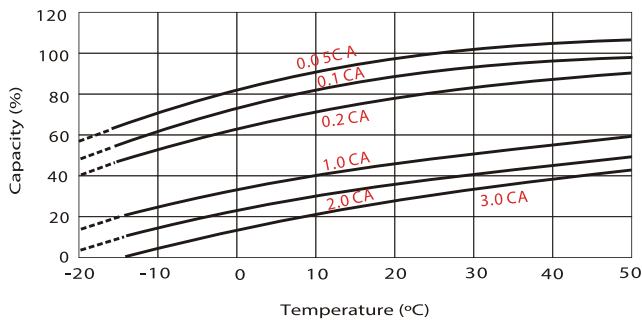

Effect of Temperature on Long Term Float Life

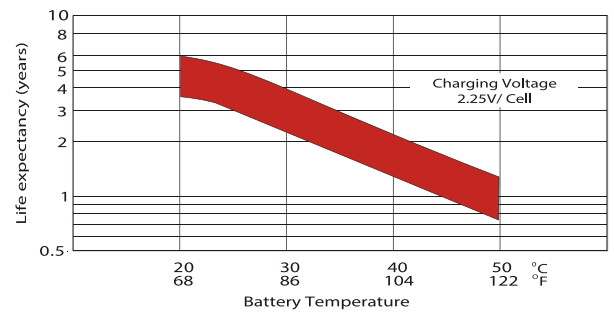

Self Discharge Characteristics

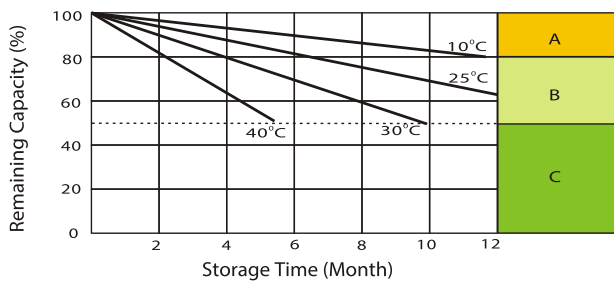

- A** No supplementary charge required
(carry out supplementary charge before use if 100% capacity is required)
- B** Supplementary charge required before use. Optional charging way a below:
 1. Charged for above 3 days at limited current 0.25 CA and constant voltage 2.25V / cell.
 2. Charged for above 20 hours limited current 0.25CA and constant voltage 2.45V / cell.
 3. Charged for 8-10 hours at limited current 0.05 CA.
- C** Supplementary charge often fail to recover the capacity.
The battery should never be left standing till this is reached.

IMPORTANT NOTE: The specifications presented herein are subject to revision without notice.