



# M45-12 SLD M

## SPECIFICATIONS

**Nominal Voltage (V)** 12V

### Nominal Capacity

20 hour rate ( 2.25A to 10.50V )	45Ah
10 hour rate ( 4.275A to 10.50V )	42.75Ah
5 hour rate ( 7.65A to 10.20V )	38.25Ah
1C ( 45A to 9.60V )	25.5Ah
3C ( 135A to 9.60V )	18Ah

**Weight** Approx. 31.9Lbs. (14.5kg)

**Internal Resistance (at 1KHz)** Approx. 7 mΩ

**Maximum Discharge Current for 5 seconds :** 540A

### Operating Temperature Range

Charge	-15°C ( 5°F ) to 40°C (104°F )
Discharge	-15°C ( 5°F ) to 50°C (122°F )
Storage	-15°C ( 5°F ) to 40°C (104°F )

### Charge Retention (shelf life) at 20°C ( 68°F )

1 month	92%
3 months	90%
6 months	80%

### Charging Methods at 25°C ( 77°F )

**Cycle Use :** Charging Voltage 14.4 to 15.0V  
Coefficient -5.0mv / °C / cell  
Maximum Charging Current : 13.5A

**Standby Use :** Float Charging Voltage 13.50 to 13.80V  
Coefficient -3.0mv / °C / cell

**Case Material :** ABS  
(Option : UL94 HB & UL94 V-0 Flame Retardant Case Material)

**Terminal :** F8

### Terminal Hardware Torque Value :

Recommended	M6: 7 Nm (71kgf-cm)
Maximum Allowable	M6: 9 Nm (92kgf-cm)

## Maintenance-Free Rechargeable Sealed Lead-Acid Battery



## DIMENSIONS

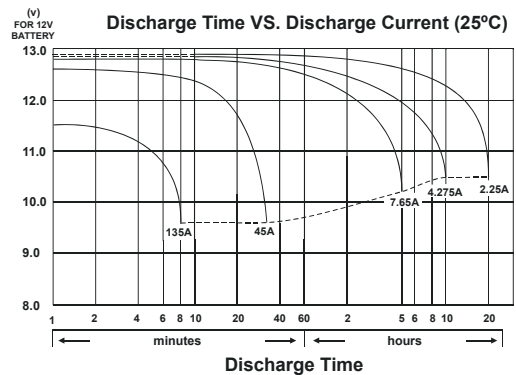
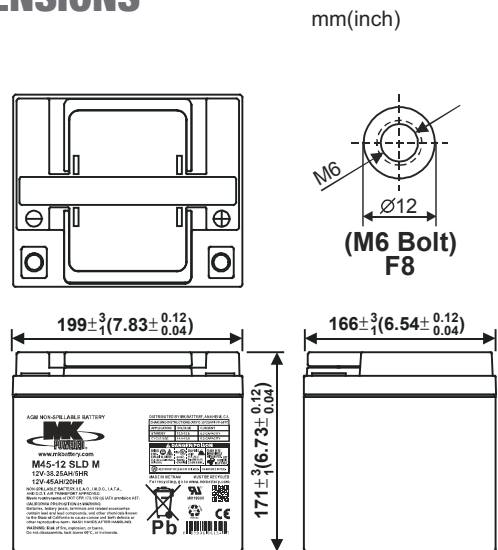

## MK Battery

1631 South Sinclair Street • Anaheim, California 92806

Toll Free: 800-372-9253 • Fax: 714-937-0818 • E-mail: sales@mkbattery.com

