



CHARACTERISTIC / CARATTERISTICHE

Volt	12V	
Capacity / Capacità	20h	80Ah
	5h	68Ah
Internal Resistance	Full Charged Battery 25°C ≤6.5mΩ	
Capacity affected by Temperature / Effetti delle temperature sulla capacità	40°C	102%
	25°C	100%
	0°C	85%
	-15°	65%
Self-Discharge 25°C Capacity / Autoscarica a 25°C	after 3 month storage	90%
	after 6 month storage	80%
	after 12 month storage	62%
Charge (Costant Voltage 25°C)	Float	Volt 13.6 - 13.8V
	Charge	Max.20Amp. 14.4 - 15 Volt

CHARACTERISTIC / CARATTERISTICHE

Battery dimensions / Dimensioni batteria			
L/L	W/P	H/A	Tot - H/A
260	169	211	215
Box Dimensions / Dimensioni scatola			
L/L	W/P	H/A	
275	183	272	
Weight / Peso			24.50Kg
Terminal / Terminali			M6
Case / Contenitore			ABS

Amp. (25°C)

F.V/Time	5min	10min	15min	30min	45min	1h	2h	3h	5h	8h	10h	20h
1.60V				89.8	64.4	51.0	30.0	22.1	14.9	10.2	8.40	4.36
1.65V				85.4	61.9	49.5	29.0	21.4	14.6	10.1	8.24	4.32
1.70V				81.4	59.7	47.6	28.2	20.8	14.3	9.9	8.16	4.27
1.75V				77.2	57.0	45.7	27.5	20.3	14.1	9.8	8.08	4.23
1.80V				73.7	55.0	44.1	26.5	19.7	13.8	9.6	7.80	4.16

Watts (25°C)

F.V/Time	5min	10min	15min	30min	45min	1h	2h	3h	5h	8h	10h	20h
1.60V				167.6	120.1	95.2	56.0	41.2	27.8	18.9	15.7	8.1
1.65V				159.2	115.5	92.4	54.2	39.8	27.3	18.8	15.4	8.1
1.70V				151.9	111.3	88.8	52.7	38.8	26.7	18.5	15.2	8.0
1.75V				144.0	106.4	85.2	51.3	37.9	26.3	18.2	15.1	7.9
1.80V				137.4	102.5	82.2	49.4	36.7	25.7	17.9	14.9	7.8

ZGL120070

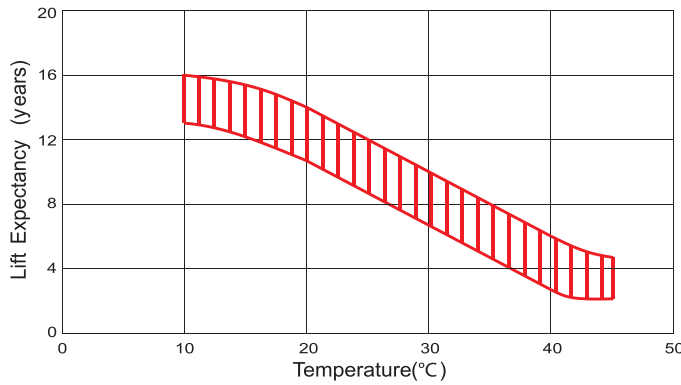
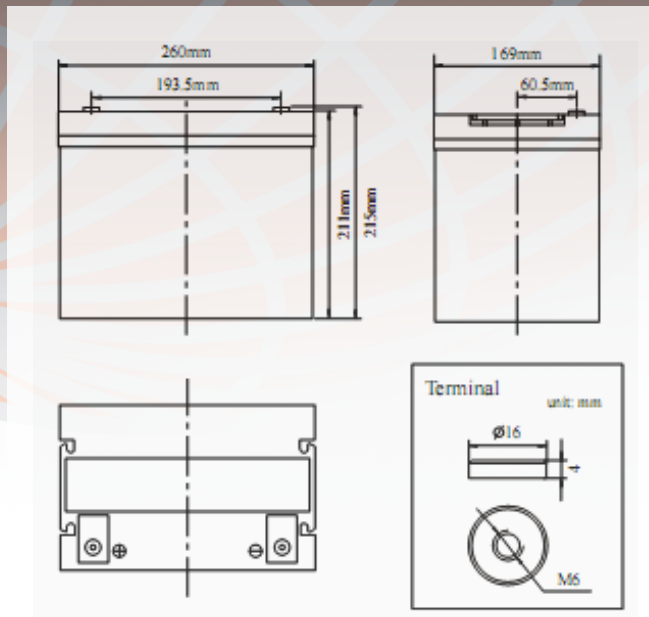

Charging characteristics

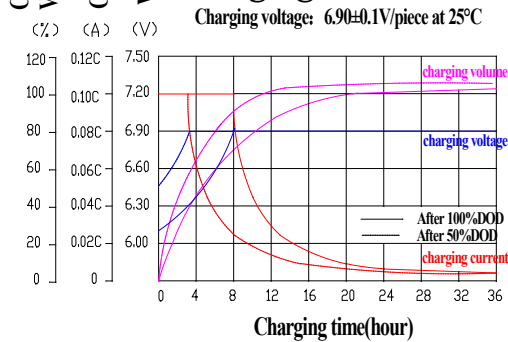

Temperature effect on battery self-discharge

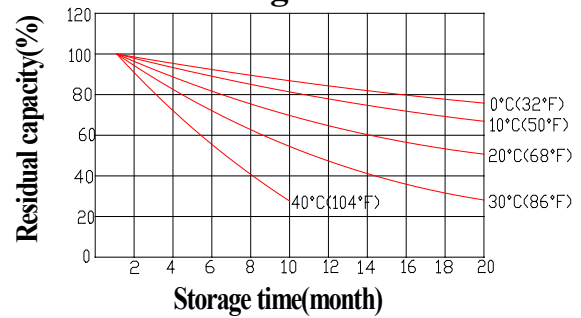

Discharge characteristics (25 $^{\circ}\text{C}$)

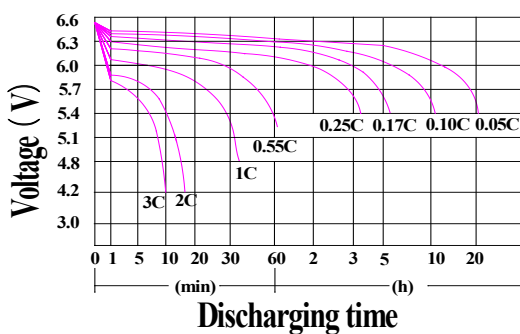

Temperature effect on capacity

