

CODICE/CODE: ZNC120078

Batteria sigillata AGM, non adatta per impieghi ciclici
 AGM maintenance free battery (not DEEP-CYCLE)



Volt		12V
Capacity/capacità (20h)		100Ah
Capacity/capacità 25°C	10h	94Ah
	5h	83Ah
	1h	58Ah
Internal Resistance	Full Charged Battery 25°C	≤4.5m Ω
Capacity affected by Temperature	40°C	102%
	25°C	100%
	0°C	85%
	-15°C	65%
Self-Discharge 25°C Capacity	after 3 month storage	90%
	after 6 month storage	80%
	after 12 month storage	62%
Charge (Constant Voltage) 25°C	Float	13.6-13.8Volt
	Charge	Max. 30Amp. 14.4-15.0Volt

Battery Dimensions/ Dimensioni batteria	L/L	307mm
	W/P	169mm
	H/A	211mm
	Tot- H/A	215mm
Box Dimensions/ Dimensioni scatola	L/L	
	W/P	
	H/A	
Weight/peso		29Kg
Terminal/terminale		M6
Case/contenitore		ABS

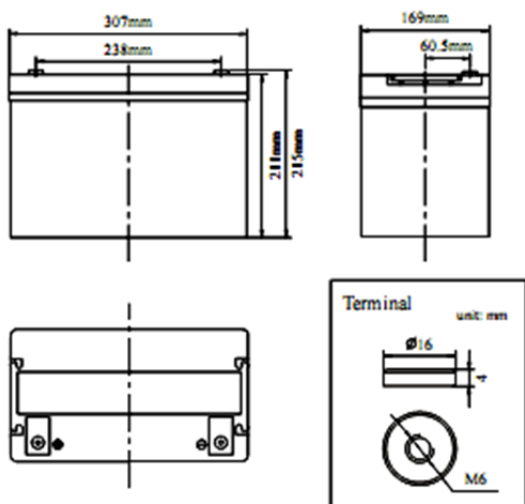

Temperature effect on float life

Float charging voltage $\pm 0.01V$ (25°C)

